

Initial pressure drop as a function to the air volume in the new filter

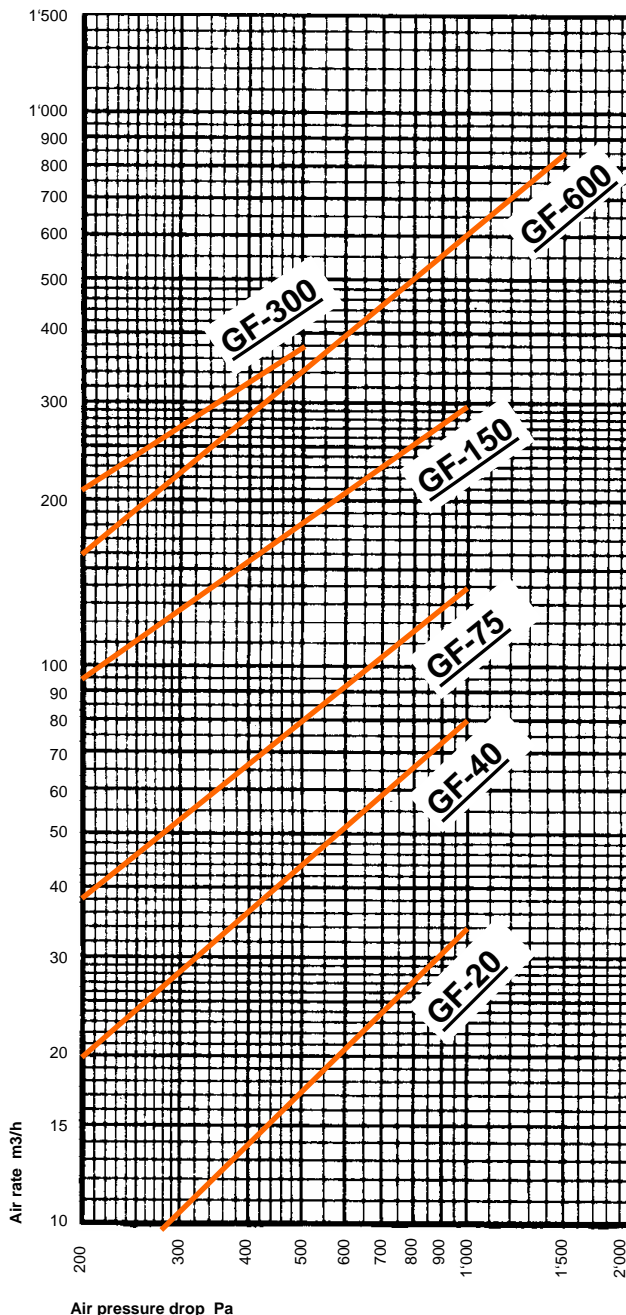

General requirements for gasfilters

- Gas-tight housing
 - Maximum moisture content of the active carbon in processing < 5%
- Entire filter insensitive to
- Vibrations during transport
 - Pressure changes ± 0.4 bar due to temperature variations

Capacity of the gasfilter

The gasfilter resists the blast impulse wave in the junction pipe of the filter

peak excess pressure P sp	1.3 bar
duration or impulse	5 ms
Impulse	250 Ns / m ²

Performance of activated carbon

The performance of activated carbon against chemical war gases is tested with substitute gases:

- Chloropicrin for the physical adsorption (nerve gases)
- Hydrocyanic acid and chlorocyanide for the chemical adsorption

Test requirements

D = dry carbon is equal to or less than 3 % rh
 M = moist carbon, pre-conditioned 20°C 90% rh
 testing air with substitute gas 20°C 70% rh

Adsorption capacity

Substitute gas		Test concentration	Adsorption capacity of carbon
		g / m ³	g / l
Chloropicrin	d	16	220
Chloropicrin	m	16	110
Chlorocyanide	d	5	45
Chlorocyanide	m	5	45
Hydrocyanic acid	d	2	20

Time or resistance: Calculation example

Adsorption: Gas concentration 30 mg / m³

Question: Time of resistance for gasfilter GF-150 against Chloropicrin d ?

Calculation: Carbon content of filter GF-150 = 66 l
 Adsorption capacity of 66 l carbon =
 $66 \times 220 = 14'520$ g
 Adsorption capacity of GF- 150
 $150 \text{ m}^3/\text{h} \times 30 \text{ mg}/\text{m}^3 = 4,5 \text{ g}/\text{h}$
 Theoretical time of resistance for the gasfilter = $14'520 \text{ g}/4,5 \text{ g}/\text{h} = 3'226 \text{ h}$
 or $3'226 \text{ h} = 134 \text{ days}$

Shock resistance

GF 20	max. velocity	0.63 m/sec
GF 40	max. acceleration a =	6.3 gn
GF 75	(corresponds to German class RK 0.63)	
GF 150	max. velocity	1.6 m/sec
GF 300	max. acceleration a =	16 gn
GF 600		

Function of gasfilter

The polluted air first passes through the absolute filter which retains the finest impurities, solid and liquid as well as radioactive particles. Then the air flows through the activated carbon filter which can adsorb gases by physical and chemical action.

GF-75

sectional drawing

consisting of:

1. filter casing
2. high efficiency filter
3. activated carbon filter
4. air inlet with closure
5. air outlet with closure
6. pressure compensation screw
7. floor fastening bracket
8. steel dowels
9. plastic cover

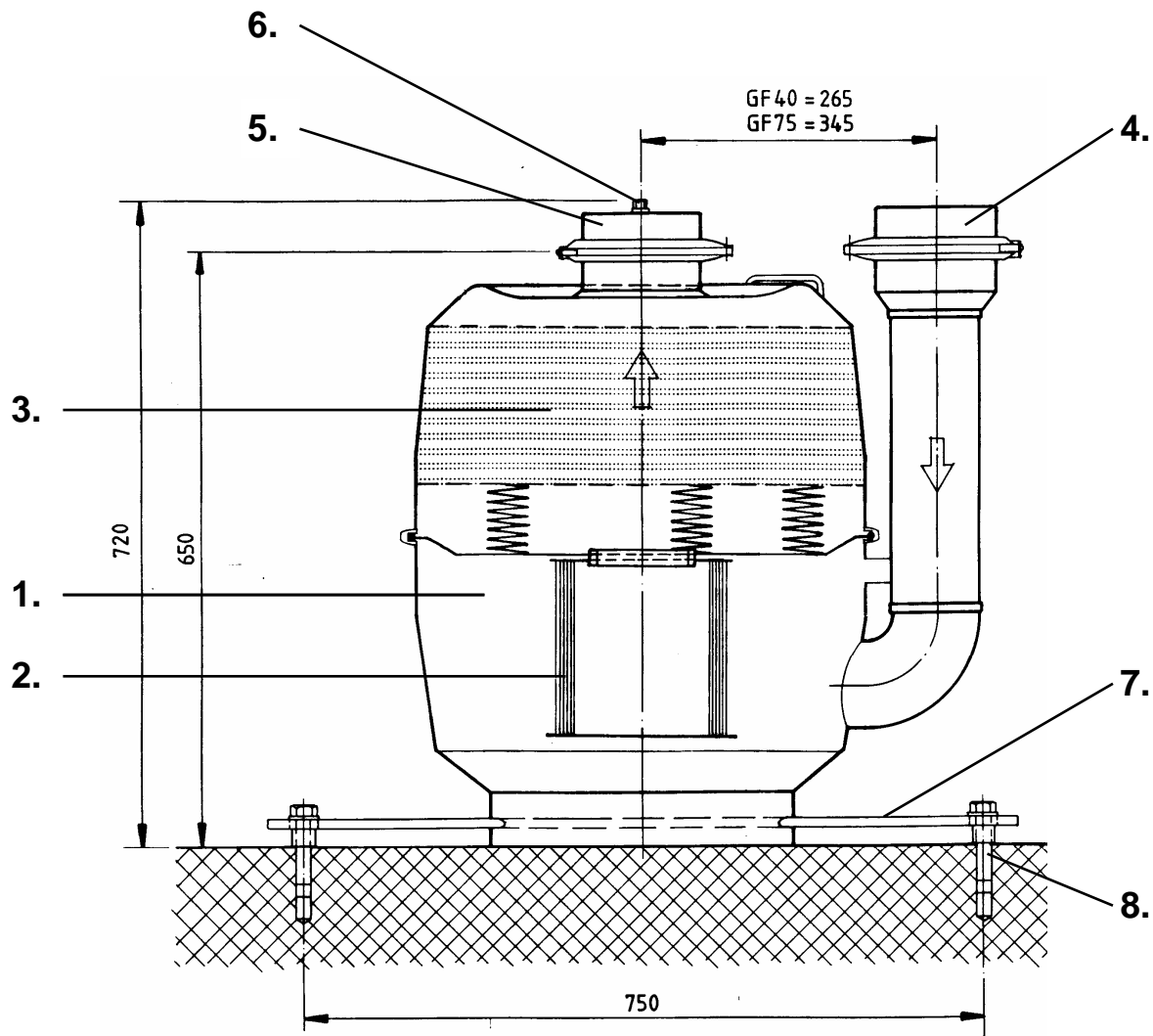

Mounting instructions see page 05.mont.123

Maintenance/ check 05.maint.133

Proviso for technical change

Gasfilter GF-75

made by : LUNOR G.Kull AG, CH-8041 Zürich

Design according to the directives of the Swiss Federal Office of Civil Defence. Type tested and approved by the Armament Technology and Procurement Group.

Consisting of:

Filter casing, high efficiency filter, activated carbon filter, air inlet with closure, air outlet with closure, pressure compensation screw, floor fastening bracket, steel dowels, plastic cover

Type of gasfilter GF-75 pcs

Attest Nr. T 75-003

Air rate 75 m³ / h

Pressure drop approx. 460 Pa

Approx. weight 42 kg

Convenient to Lunor Ventilation unit VA-75

1. Place the gasfilter and the floor fastening bracket exactly. Mark the holes for the dowels. Distance from the wall min. 50 mm.
2. Drill the holes according to the dowel suppliers instructions. Recommended dowel type: Hilti HST M 10/50
3. Clean and blow out the dowel-holes.
4. Turn the nut of the dowel to upper edge of the thread.
5. Place the gasfilter and the floor fastening bracket definitive.
6. Stick the dowel through the clip and drive in with light hammerblows, until the washer is self supporting against the floor fastening bracket.
8. Tighten dowels with a torque wrench, torque as in table

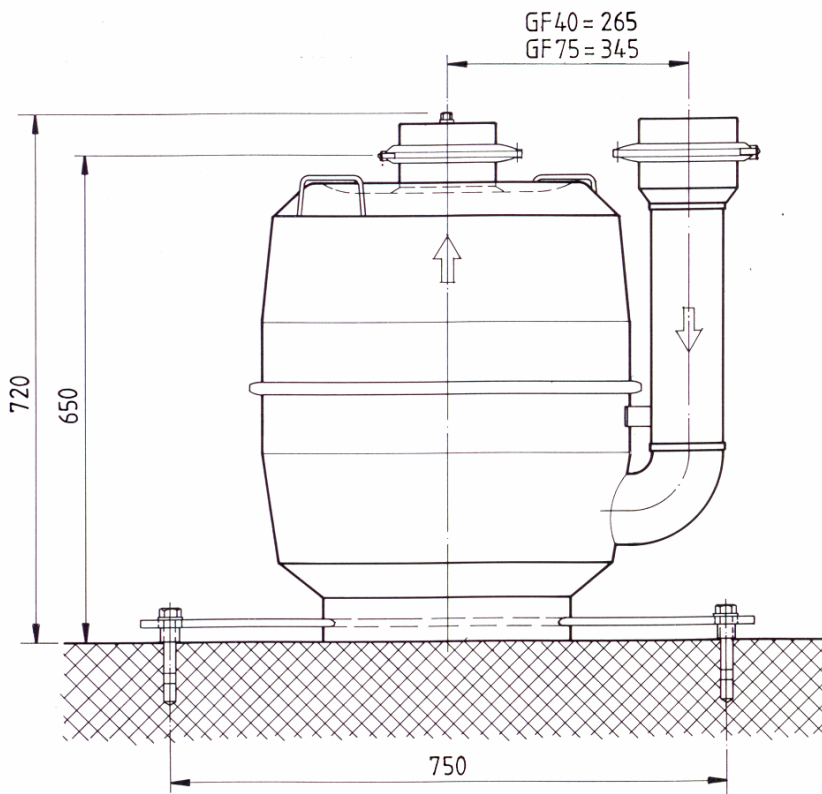
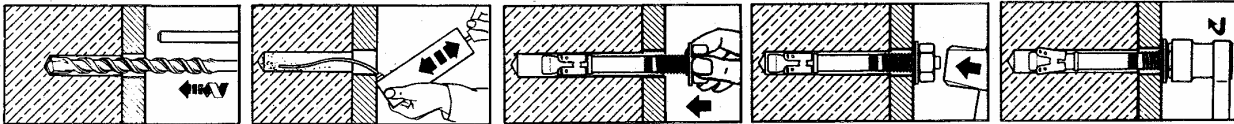

GF-75	
dowel type	Hilti HST M 10/50
quantity	2 pieces
borehole diameter	10 mm
borehole depth	110 mm
tightening torque	45 Nm
quantity of floor fastening bracket	1 piece
slotted hole diameter	13 mm

If you make use of other dowel types, they must have an attest Nr. of the Armament Technology and Procurement Group and possess an approved charge of 3,5 kN.

In this case, you have to pay attention that the corresponding value like the borehole depth, the borehole diameter and the tightening torque get observed appropriately to the specifications of the suppliers.

Proviso for technical change

Function:

The gasfilter absorbs chemical and bacteriological bodies from the fresh air.

Generality:

The air in- and outlets are hermetically closed and sealed. In peace time the filter must **never** be opened. Tests carried out with gasfilters over 20 years old have proven that the filters remain operative over a long period of time, provided they are kept sealed.

Maintenance interval:

Annually

Maintenance / Check:

- are the air in – and outlets closed and sealed ? Check closing and seal for damages.
If the filter is open, it has to be re-conditioned by the supplier.
- check casing for corrosion and if necessary touch up.
- check floor fixing bolts for tightness.
- check weight of gasfilter and with weight given on name plate. The **max. permissible weight increase** due to absorption of humidity of carbon is for the **GF-75 = 360 g**.
If the increase is beyond this figure the gasfilter has to be re-conditioned by the supplier.