

A-A (1:5)

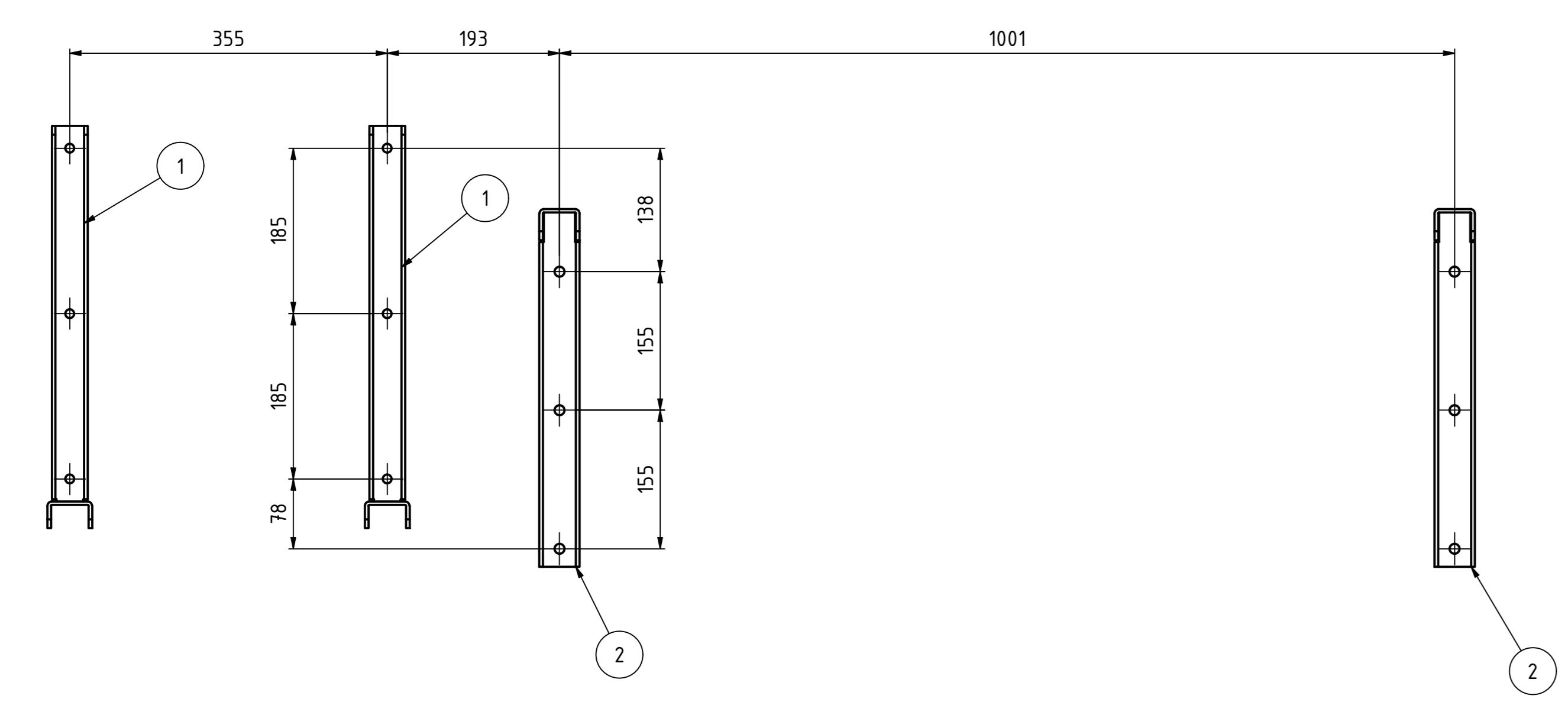

Montagehinweise beachten!

Pos.	Benennung / Merkmale	Stk.	Material	Bemerkung
1	Konsole L	2	Stahl verzinkt	9710
2	DT 800/1100 Wandkonsole (Paar)	2	Stahl verzinkt	9760
3	Lunor Adsorptionstrockner DT800/1100	1		
4	AirBox zu DT800/1100 mit WRG	1		9700
5	Muffe (VBR) NW160 - 130	1	Stahl verzinkt	
6	Muffe (VBR) NW250 - 130	1	Stahl verzinkt	
7	Drosselklappe NW160	2	Stahl verzinkt	
8	Drosselklappe NW250	1	Stahl verzinkt	
9	Schwingelement B Ø30x30 (M8) + Linsensch. M8x10 (Flansch)	4	Material Nr. 10020638	

Material / Material	Normenstand / Norm Material	Oberfläche / Surface	Gewicht / Mass
			103

Blatt / Foil	AG	Zeichnung / Drawing	Datum / Date	Name/Nom
1 / 1			15.08.2016	yun
		Maßstab / Scale	27.10.2022	lrs
		Änderung / Change		
		Arbeitsnummer / Item Number		

Produkt / Product	Produkt / Product	Revisionsnummer / Revision Number	Rev.
LUNOR	G. Kujil AG Attenhofstrasse 127, 8541 Zurich Tel: 044 488 95 90 Fax: 044 488 98 10	07800 / DT1100	9750 e