

ANSICHT A

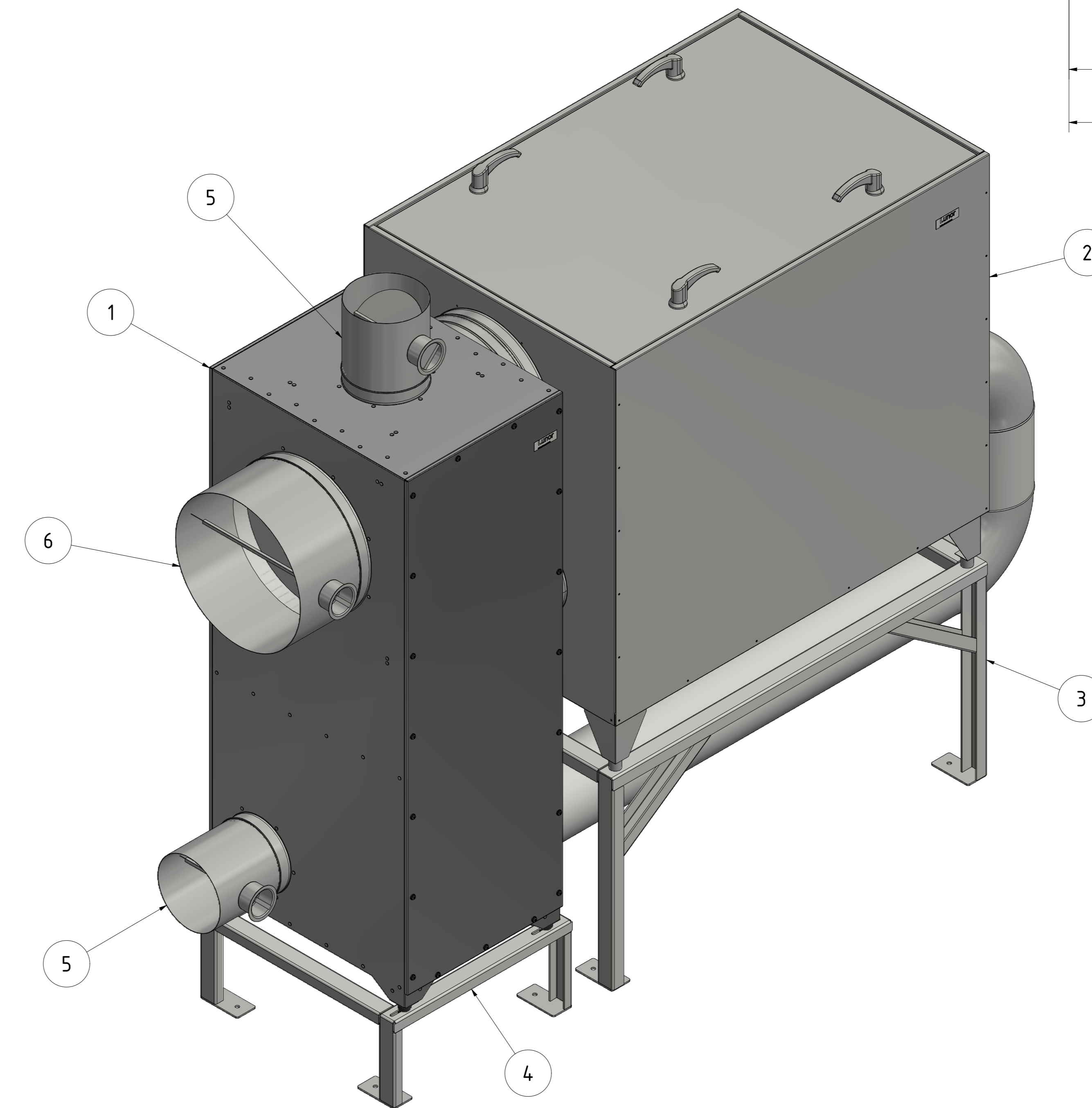
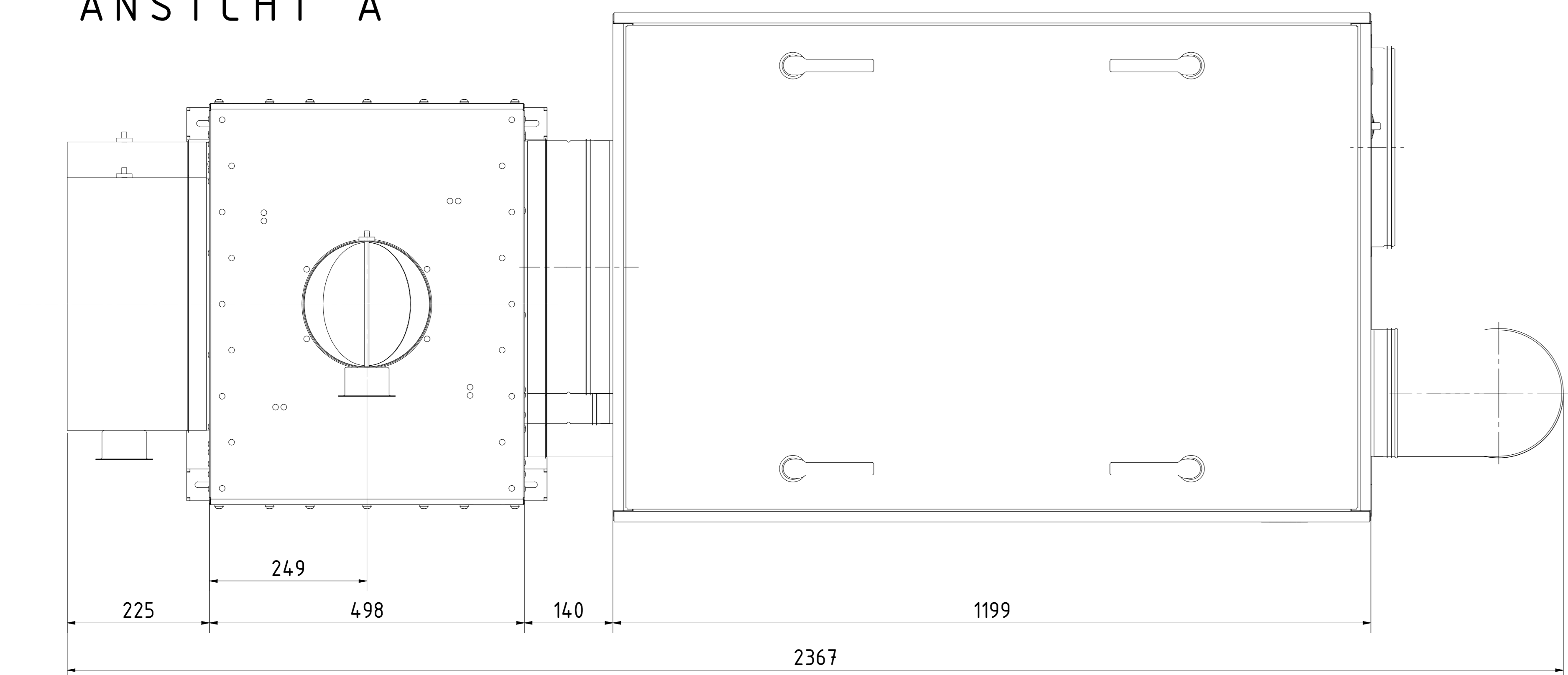

Montagehinweise beachten!

Pos.	Benennung / Merkmale	Stk.	Material	Bemerkung
1	AirBox X300 mit WRG	1		9800
2	Adsorptionstrockner DT 1300-3300	1		
3	Konsole zu Lunor DT1300-3300	1	Stahl verzinkt	9850
4	Konsole zu AirBox DT3000 mit WRG	1	Stahl verzinkt	9855
5	Drosselklappe NW200	2	Stahl verzinkt	
6	Drosselklappe NW400	1	Stahl verzinkt	
7	Muffe (VBR) NW200 - 130	1	Stahl verzinkt	
8	Muffe (VBR) NW400 - 130	1	Stahl verzinkt	

Material / Material		Oberfläche / Surface		Gewicht / Mass	
				126.15	
Montageanleitung					
für Lunor DT1300/2300/3300					
Adsorptionstrockner mit AirBox WRG					
Blatt / Page	AD	Zeichner	Datum / Date	Name/Nom	Rev.
1 / 1		17.07.2020	17.07.2020	bac	
Maßstab	Format	Charge	31.05.2023	lrs	
1:5					
Produkt				Bestellnummer	Rev.
LUNOR G. Kujil AG				9840	b
Attenhofstrasse 127, 8541 Zornheim					
Tel: 0441 488 90 90 Fax: 0441 488 98 10					
Arbeitsnummer / Item Number					
Arbeitsnummer					